

FLAT TOP SLAB

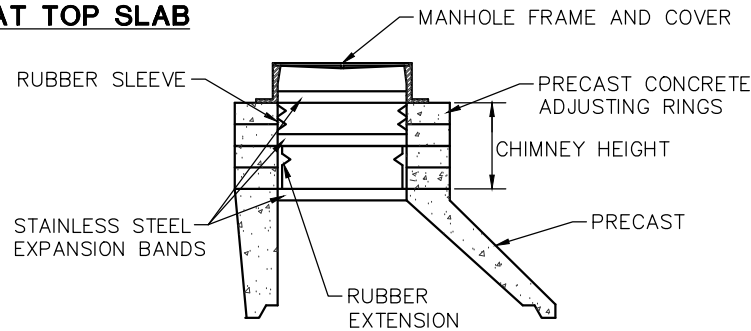

INTERNAL MANHOLE CHIMNEY SEAL

(REQUIRED BY ALL SANITARY APPLICATIONS)

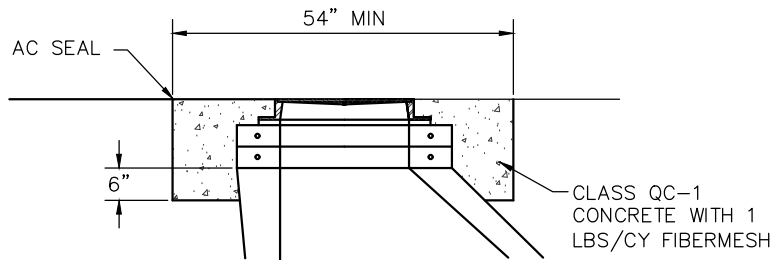

MANHOLE REPAIR CASTING CONSTRUCTION

NOTES:

1. PRECAST CONCRETE ADJUSTING RINGS- ENCASE WITH CONCRETE 6" DOWN FROM BARRELL TOP AND UP TO FLUSH WITH SURFACE. METAL ADJUSTING RINGS WILL NOT BE ALLOWED.
2. SET MANHOLE, PRECAST CONCRETE ADJUSTING RINGS AND CASTING AND PAVE OVER MANHOLE. THEN DIG OUT, ENCASE COLLARS AND CASTING AS PER DETAIL WITH CONCRETE TO THE SURFACE.

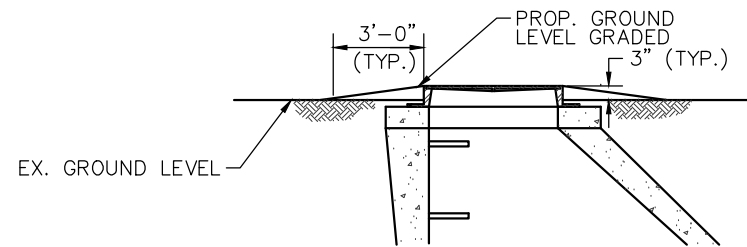

TYPICAL OFF STREET MANHOLE GRADING

NOTES

- A. MANHOLE STEPS SHALL BE SECURLY INSTALLED INTO EACH MANHOLE SECTION, BY THE MANUFACTURER, PRIOR TO DELIVERY TO THE JOB SITE.
- B. MANHOLE STEPS SHALL BE PFS-1 STEP BY M.A. INDUSTRIES OR EQUIVLENT.